

Effect of Dissolved Lubricating Oils on the Viscosity of Alternative Refrigerants

Y. N. Chang¹ and A. Nagashima¹

Received March 31, 1993

The operation of refrigeration systems involves the circulation of a working fluid which is actually a mixture of refrigerant and lubricant oil. Since the viscosity of oil and that of refrigerants normally differ by up to a factor of 4, the effect of dissolved oil is very large. In order to use new alternative refrigerants, accurate information on thermophysical properties of refrigerant-oil mixtures is needed. In the present study, the viscosity of refrigerant-oil mixtures was measured for HCFC-123 + 3GSD and HFC-134a + PAG in the compressed liquid region with a falling-ball viscometer. The temperature range of the measurements was 253–333 K.

KEY WORDS: falling-ball method; HCFC-123; HFC-134a; refrigerant-oil mixtures; viscosity.

1. INTRODUCTION

Accurate information on the properties of refrigerants is essential for developing and designing refrigeration systems. Among various properties, the liquid viscosity is very sensitive to changes in the composition and the change in the viscosity has especially a serious influence on the cycle performance and the heat-transfer performance. Working fluid and heat-transfer fluid circulating in actual refrigeration systems or heat-pump systems are generally not pure liquids but mixtures with lubricating oil, water, or other impurities. The viscosity of lubricating oil is 5000 to 10,000 times greater than that of the refrigerant, and therefore, contamination of the oil causes a significant change in the viscosity of working fluids. Not only in the calculation of circulation power but also in heat-transfer

¹ Department of Mechanical Engineering, Keio University, 3-14-1 Hiyoshi, Yokohama 223, Japan.

calculations based on nondimensional numbers, this change in viscosity brings considerable uncertainty.

On the other hand, the problem of chlorofluorocarbon (CFC) refrigerants for ozone depletion and greenhouse effects has created an urgent need to develop alternatives. This means that there is also an urgent need to study the behavior of alternatives under the contamination of lubricating oil. Some information on conventional CFC-oil mixtures has been reported in the past by Little [1], Albright and Mandelbaum [2], and Parmelee [3]. However, similar information of HCFC-oil and HFC-oil mixtures is not available. A difficulty with these mixtures is that theoretical or empirical prediction methods are not applicable, since information such as molecular structure and molecular weight of the lubricating oil is often not available. Therefore, experimental determinations are needed for quantitative analysis.

In the present study, the concentration dependence and the temperature dependence of the viscosity of mixtures were experimentally studied for two refrigerant-oil mixtures, namely, HCFC-123 + 3GSD (150 SUS. SUNICO OIL) and HFC-134a + PAG (polyalkyleneglycol). These refrigerants and lubricating oils are used in such industrial applications as car coolers and refrigerators. The applicable experimental methods for these mixtures are limited, since the viscometer has to cover an extremely wide range of viscosity. Hence, the falling-ball method was selected in the present study. A high-pressure viscometer was constructed and used for measurements at pressures slightly higher than the saturation pressure and in the temperature range 253–333 K.

2. EXPERIMENTAL METHOD AND SELECTION OF THE BALL

The principle of the falling ball method is based on Stoke's law [4]. Although it is one of the well-established methods, it is normally very difficult to operate an actual falling-ball viscometer under ideal conditions. Selection of the proper material and size of the ball is very important to assure that the Reynolds number is low enough. The actual working equation is

$$\eta = \frac{d^2(\rho_b - \rho)g}{18vk_D} F_w \quad (1)$$

where ρ_b is the density of the ball, ρ the density of the fluid, η the viscosity, d the diameter of the ball, g the gravitational constant, and v the fall velocity. The factors F_w and k_D are correction factors for the wall effect and the inertial effect, respectively [5]. The effect of the wall is not negligible

and the correction factor F_w has been derived by Faxen [6] as a function of the diameter of the ball d and the inner diameter of the cylindrical vessel D :

$$F_w = 1 - 25.104(d/D) + 2.09(d/D)^3 - 0.95(d/D)^5 \quad (2)$$

The other factor k_D is for the inertial correction and is a function of the Reynolds number. Various authors have derived equations for k_D by analyzing flow conditions. For Reynolds numbers Re smaller than unity, the correction factor k_D is given as [7]

$$k_D = 1 + 3 Re/16 \quad (3)$$

where $Re = \rho vd/\eta$ is the Reynolds number.

Since the Reynolds number cannot be determined unless the exact value of the viscosity is given, iterative calculations are needed. Faxen [6] also derived the factor for the inertial correction. A popularly used equation of k_D for measurement with higher Reynolds numbers is due to Goldstein [8].

However, in the case of a practical viscometer like the one used in the present study, both the diameter and the height of the test cell are finite, and therefore both corrections have to be considered simultaneously. Sutterby [5] made an extensive study of these corrections for higher Reynolds numbers and for the wall effect, theoretically and experimentally. He combined these effects and produced a convenient table of correction factors which is applicable for measurements with Reynolds numbers up to 4. In the present study, Sutterby's value was used in most of the range. However, at some points the range of the Reynolds number exceeded 4. For $Re > 4$, Goldstein's equation was used. For some measurements where the Reynolds number was close to 4, the viscosity calculations were made with both Sutterby's and Goldstein's correction factors, and the results were compared. If the difference was large, the result was discarded.

As mentioned before, the viscosity of lubricating oil is about 10,000 times greater than that of refrigerants. There is no other method which can cover this wide range of viscosity. Therefore, it is unavoidable to make some measurements with Reynolds number exceeding 4, or even 10 at a few points. Although the corrections of Sutterby or Goldstein were applied for these measurements, a larger uncertainty is to be expected.

Balls made of Nylon, Delrin (acetal resin by Du Pont), styrol, and glass of various sizes were tested. Nylon balls (1.633 + 0.01) mm in diameter and Delrin balls of (1.592 + 0.03) mm were used in most of the measurements. Densities and their temperature and pressure dependence for these materials were taken from Ref. 9.

3. EXPERIMENTAL APPARATUS AND PROCEDURES

The experimental setup is shown in Fig. 1. Important parts of the apparatus are composed of a pressure vessel which houses the test section, the thermostatic bath with thermometers, the pressure system, and the fall-measurement system. The measurements were conducted at temperatures below and above the boiling point of the test fluid. In order to pressurize the sample liquid, nitrogen gas was introduced on the other side of a polychlorovinylidene membrane in the separator shown in Fig. 2. Solubility of the membrane material into the refrigerant was not known, so that the separator was set far enough from the test section via a sufficiently long tubing. The membrane was frequently replaced and no damage was found when checked after its use. Comparisons of measurements before and after refilling with the sample liquid never showed any appreciable differences. Measurements were made at pressures about 0.1 MPa higher than the saturation pressures which were calculated with Oguchi's equations [10] and also estimated from Ref. 11. The temperature and its distribution in the thermostat were measured with a quartz thermometer and five thermocouples. The cyclic change of the air-bath temperature was within ± 0.1 K.

Each ball was discharged one by one to fall from the top of the test section by the rotational mechanism shown in Fig. 3, which could store

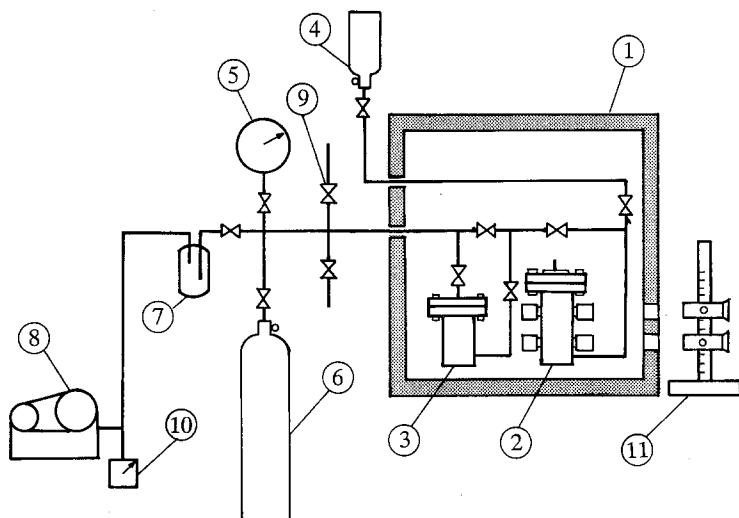

Fig. 1. Experimental setup for viscosity measurements. 1, Thermostat; 2, viscometer; 3, separator; 4, refrigerant; 5, Bouldon gauge; 6, N₂ bomb; 7, glass cylinder; 8, vacuum pump; 9, safety valve; 10, vacuum gauge; 11, traveling microscope.

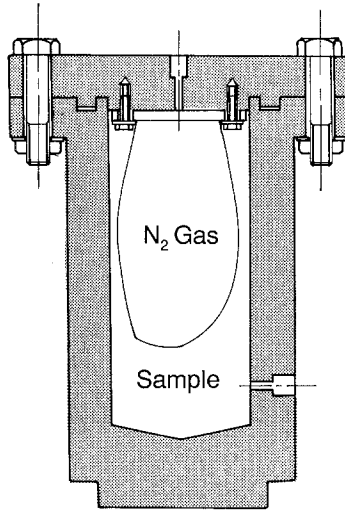

Fig. 2. Separator.

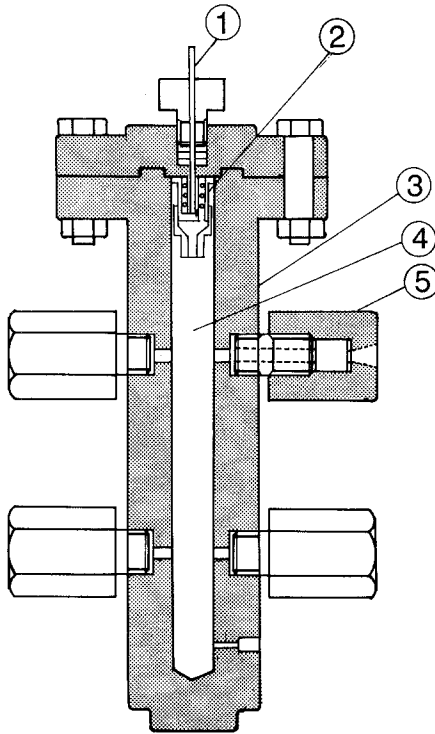

Fig. 3. Pressure vessel and test section. 1, Rod for ball discharge; 2, rotating discharge; 3, pressure vessel; 4, sample liquid; 5, windows.

about 30 balls. The fall time was measured by a stopwatch observing the ball by a traveling microscope through high-pressure windows. The actual time of a fall ranged from 1.4 to 832 s. The measurements were repeated three times at each temperature. The reproducibility of repeated measurements was better than 2%.

4. PREPARATION OF MIXTURES AND MEASUREMENT OF DENSITY

Mixtures were prepared in a mixing bomb and then introduced into the test section at temperatures sufficiently below the boiling temperature of the sample liquid. After evacuation, lubricating oil was brought into a mixing bomb. The refrigerant vapor was then introduced and condensed in the bomb cooled by dry ice. The composition was determined by measuring the weight of the bomb and the content on a balance at each step. To avoid the possibility of loss of refrigerant by evaporation, most measurements were made with new samples (mixtures).

The viscosity measurements were made at six compositions for HCFC-123 + 3GSD and at three compositions for HFC-134a + PAG. Molecular weights, melting points, and normal boiling points of pure components are given in Table I. In the calculation of the viscosity from Eq. (1), the density of the sample fluid is needed. No data sources were found in the literature for the density of these mixtures of refrigerant and lubricating oil.

Prior to the viscosity measurements of HCFC-123 + 3GSD, therefore, density measurements were carried out for mixtures at these compositions and at temperatures up to 293 K (for lubricating oils, up to 333 K). A float-type densimeter was used for the measurements. At temperatures above 303 K, measurement of the density was difficult by this type of densimeter, because of the higher vapor pressure of refrigerants. As an example the

Table I. Characteristics of Pure Samples

	HCFC-123	HFC-134a	3GSD	PAG
Chemical formula	CHCl_2CF_3	$\text{CF}_3\text{CH}_2\text{F}$		
Molecular weight	152.93	102.03		
Freezing temp. (K)	166.15	165.15	233.5	233.15
Boiling temp. (K)	303.78	247.00	736.15	
Density ($\text{kg} \cdot \text{m}^{-3}$) (273.15 K, 1 atm)	1522.79	1292.87	1028.28	921.23
Viscosity ($\text{mPa} \cdot \text{s}$) (273.15 K, 1 atm)	0.57	0.27	436.12	477.15

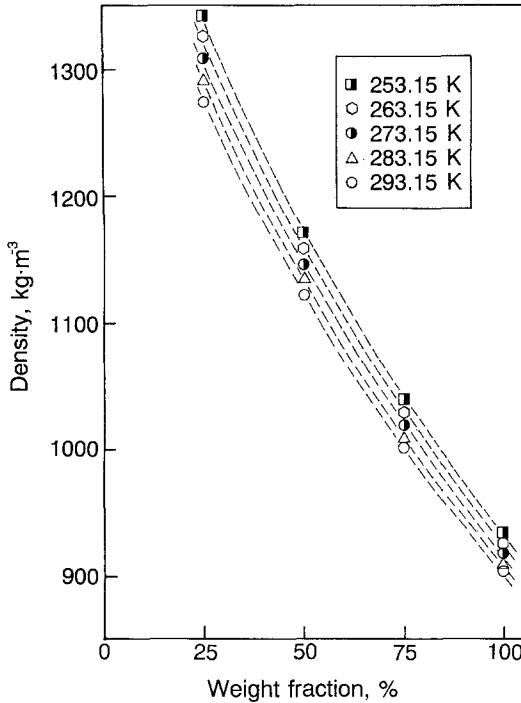

Fig. 4. Measured density of HCFC-123 + 3GSD mixtures.

measured density values of HCFC-123 + 3GSD mixtures are shown in Fig. 4. Their composition dependence is almost linear.

Simple equations were adopted to reproduce density data of lubricating oils. For the density of pure refrigerants, equations of the saturation density correlated by Maezawa et al. [12] were used. With these densities for the pure refrigerant and the lubricating oil, the density ρ_{mix} of the mixture was calculated by the following mixing rule given in the *ASHRAE Systems Handbook* [13]:

$$\rho_{mix} = \frac{\rho_r}{1 - (1 - w)(1 - \rho_r/\rho_o)} \tag{4}$$

where ρ_{mix} is the density of the mixture, ρ_r the density of the refrigerant, ρ_o the density of the oil, and w the weight fraction of the oil in the mixture.

Densities calculated from Eq. (4) were compared with measured density data for mixtures in the temperature range 253–293 K; average deviations were 0.16% for HCFC-123 + 3GSD. The standard deviation of

measured data from the values calculated with the ASHRAE equation was 0.2% and the maximum deviation was $\pm 0.7\%$. The estimated error in density is 0.35% for both systems.

5. RESULTS AND DISCUSSION

Experimental determinations of the viscosity were performed for six compositions (including pure 3GSD oil) of HCFC-123 + 3GSD and for three compositions (including pure PAG oil) of HFC-134a + PAG. The temperature range of viscosity measurements was 253–333 K. The measured viscosities are presented in Tables II and III. They are also shown in Figs. 5 and 6. The values for pure HCFC-123 and HFC-134a were calculated from equations published previously [14, 15]. In these figures, no data are given in the regions where the components are not perfectly soluble. Also measurements with Reynolds numbers exceeding 6 have been omitted.

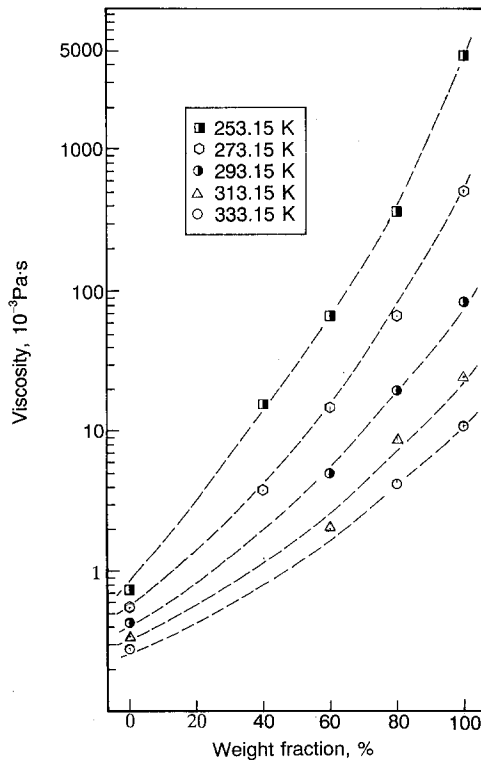

Fig. 5. Concentration dependence of the viscosity of HCFC-123 + 3GSD mixtures.

Table II. Measured Viscosity of HCFC-123 + 3GSD Mixtures

Oil content (wt %)	Temperature (K)	Re	Density (kg · m ⁻³)	Viscosity (10 ⁻³ Pa · s)
100	253.11	0.0000	935.0	4732
100	273.14	0.0001	920.3	501.5
100	293.18	0.0480	906.8	83.3
100	313.15	0.574	894.8	24.0
100	333.17	2.38	884.1	10.9
79.90	253.18	0.0004	1020	375.1
79.90	273.16	0.0493	999.8	66.7
79.90	293.18	0.634	982.9	19.2
80.06	313.07	2.52	966.4	8.98
80.06	333.20	4.75	951.3	4.75
60.03	253.11	0.11	1115.3	67.0
59.75	273.15	0.32	1094.6	14.81
59.86	293.16	3.00	1072.5	5.02
59.86	313.17	6.06	1051.5	1.88
40.00	253.14	1.33	1234.5	15.95
40.00	273.14	5.68	1206.8	3.88
0.00	253.15		1569.6	0.750 ^a
0.00	273.15		1522.8	0.567 ^a
0.00	293.15		1474.1	0.444 ^a
0.00	313.15		1423.0	0.355 ^a
0.00	333.15		1368.8	0.289 ^a

^a Values from the equation in Ref. 14.**Table III.** Measured Viscosity of HFC-134a + PAG Mixtures

Oil content (wt %)	Temperature (K)	Re	Density (kg · m ⁻³)	Viscosity (10 ⁻³ Pa · s)
100.00	273.11	0.0007	1030.1	490.5
100.00	293.15	0.0114	1010.0	132.5
100.00	313.02	0.0893	998.0	48.6
100.00	333.20	0.373	984.0	24.5
81.69	273.15	0.0254	1069.8	66.6
81.69	293.20	0.198	1043.4	27.4
81.69	313.17	0.587	1022.1	17.2
81.69	333.20	1.53	995.8	11.1
60.05	273.17	0.267	1121.0	9.44
60.05	293.15	1.98	1085.8	5.82
60.05	313.17	4.52	1052.2	3.35
60.05	333.18	6.14	1010.2	2.18
0.00	273.15		1293	0.269 ^a
0.00	293.15		1224	0.208 ^a
0.00	313.15		1146	0.161 ^a
0.00	333.15		1053	0.122 ^a

^a Values from the equation in Ref. 15.

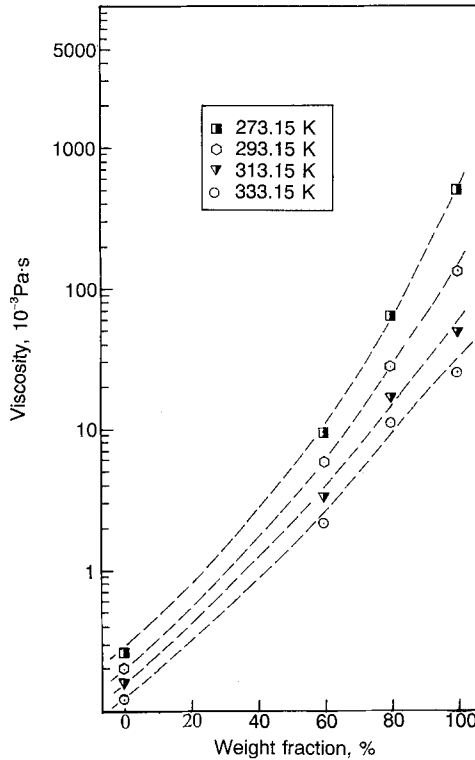

Fig. 6. Concentration dependence of the viscosity of HFC-134a + PAG mixtures.

Experimental error of the viscosity measurements was estimated from errors in measurements of the ball size, the density, and the fall time. The error in the diameter of a ball was estimated as 0.5% and that in the fall time as 0.8%. The error in the density of a ball was estimated as 0.75%. For the density of the sample liquid, the error was estimated as 0.35% for the mixtures and 0.2% for the pure refrigerants. After considering also the error in temperature measurement, the final error in viscosity measurement is estimated as 3%. However, there was a very difficult problem in the error estimation for the present mixtures. As shown in Figs. 5 and 6, the difference between the viscosity of a refrigerant and that of a lubricating oil is extremely large. This means that a small error in composition correspond to a large error in the viscosity assigned at the composition, even if the viscosity measurement itself is performed with reasonable precision. For industrial applications, it is not practical to express the experimental error of the viscosity on an ordinary absolute base only. It might be convenient

Table IV. Constants of Eq. (6) for HCFC-123 + 3GSD

i	$N(i)$	A	B	C
0	0	-4.2404833	10.023394	0
1	0.5	0	237191.7	0
2	1	-118.66953	-1304340.1	9.266272
3	1.5	0	2608030.6	0
4	2	129.26884	-2024772.6	0
5	3	-77.69668	613917.96	—
6	4	—	-129895.00	—

to represent the experimental error for this kind of special case by a logarithmic factor such as

$$\varepsilon = (\ln \eta_{\text{ex}} - \ln \eta_{\text{calc}}) / \Delta w \quad (5)$$

where η_{ex} and η_{calc} are the experimental and calculated viscosities, respectively, and where Δw is the estimated error in the composition.

The measured viscosities were correlated with the following equation as a function of the temperature and weight fraction of the lubricating oil:

$$\eta = \ln \eta = \sum_{i=0}^5 A_i W^{N(i)} + \left(\sum_{i=0}^6 B_i W^{N(i)} \right) / T_a + \left(\sum_{i=0}^4 C_i W^{N(i)} \right) T_a \quad (6)$$

where $T_a = T/100$ and T is in K. The constants for Eq. (6) are given in Tables IV and V.

The mean-squared deviations of the measured viscosity data from Eq. (6) are 2.8% for HCFC-123 + 3GSD and 3.0% for HFC-134a + PAG. Although most of the measured data are within 3% from the equation, a maximum deviation of -8% is found at 293 K for HFC-134a + PAG.

Table V. Constants of Eq. (6) for HFC-134a + PAG

i	$N(i)$	A	B	C
0	0	6.5268282	-6.3674778	-2.0187298
1	0.5	-194.3327	434.90792	0
2	1	377.27344	-811.07092	0
3	1.5	-246.94103	498.60194	0
4	2	0	0	9.7754411
5	3	0	0	—
6	4	—	0	—

6. CONCLUSION

Considering the urgent needs in industrial applications of alternative refrigerants, an experimental determination of the viscosity was carried out for two refrigerant-lubricating oil mixtures with a falling-ball viscometer. The measurements were made for HCFC-123 + 3GSD and HFC-134a + PAG in the temperature range 253–333 K. The results have been correlated with empirical equations convenient for industrial calculations.

These mixtures are typical examples of mixtures in which the thermo-physical properties of their components have extremely large differences. In the case of the viscosity of refrigerant-oil mixtures, the difference can be as large as an order of four. This causes serious trouble in calculating cycle performance and heat-transfer characteristics. Also, it is an important challenge to develop reliable experimental methods to cover this wide range of differences.

ACKNOWLEDGMENT

The authors thank Mr. T. Oshima for devoted assistance in the measurements.

NOMENCLATURE

d	Diameter of a ball (m)
D	Inner diameter of the vessel (m)
F_w	Correction factor for wall effect
g	Gravitational constant
k_D	Correction factor for inertial effect
Re	Reynolds number
T	Temperature (K)
v	Fall velocity ($\text{m} \cdot \text{s}^{-1}$)
w	Weight fraction of oil
ε	Logarithmic error factor
η	Viscosity ($\text{Pa} \cdot \text{s}$)
ρ	Density ($\text{kg} \cdot \text{m}^{-3}$)

Subscripts

a	Reduced
b	Ball
calc	Calculated

ex Experimental
mix Mixture
o Oil
r Refrigerant

REFERENCES

1. J. L. Little, *Refrig. Eng.* **60**:1191 (1952).
2. L. F. Albright and A. S. Mandelbaum, *Refrig. Eng.* **64**:37 (1956).
3. L. E. Parmelee, *ASHRAE Trans.* **70**:173 (1956).
4. M. Kawata, K. Kurase, A. Nagashima, and K. Yoshida, in *Measurement of the Transport Properties of Fluids*, W. A. Wakcham, A. Nagashima, and J. V. Sengers, eds. (Blackwell Scientific, Oxford, 1991), p. 95.
5. J. L. Sutterby, *Trans. Soc. Rheol.* **17**(4):559 (1973).
6. H. Faxen, *Ark. Math. Astron. och Fys.* **17-27**:1 (1923).
7. C. W. Oseen, *Ark. Math. Astron. och Fys.* **9-16**:1 (1913).
8. S. Goldstein, *Proc. Roy. Soc. A* **123**:225 (1929).
9. Catalog Data, Moritex Co., Ltd., USA.
10. K. Oguchi, *Proc. 11th Jap. Symp. Thermophys. Prop. Tokyo* (1990), p. 83.
11. Catalog Data, Japan Sun Oil Co. Ltd., Tokyo.
12. Y. Maczawa, H. Sato, and K. Watanabe, *J. Chem. Eng. Data* **35**:225 (1990).
13. *ASHRAE Systems Handbook* (1984), Chap. 29.
14. T. Okubo and A. Nagashima, *Int. J. Thermophys.* **13**:401 (1992).
15. T. Okubo, T. Hasuo, and A. Nagashima, *Int. J. Thermophys.* **13**:931 (1992).